

免鍵軸套



PTBNK - 8

產品代碼

軸孔徑

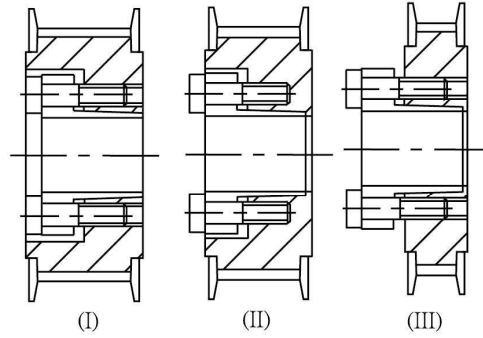
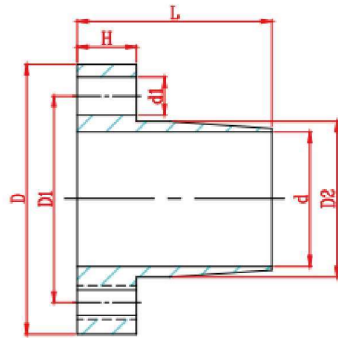

PTBNK免鍵軸套規格:

| 軸孔徑d | 使用螺絲 | | 拆卸用 攻牙孔 | D | D1 | D2 | d1 | L | H |
|------|------|------|------------|------|------|------|-----|----|-----|
| | 尺寸 | 支數 | | | | | | | |
| 6 | M3 | 4 | M3x2 | 18 | 13 | 8 | 3.3 | 16 | 4 |
| 6.35 | | | | 18.5 | 13.5 | 8.5 | | | |
| 8 | | | | 20 | 15 | 10 | | | |
| 10 | M4 | 3 | M4x2 | 25 | 18 | 12 | 4.5 | 17 | 5 |
| 11 | | | | 26 | 19 | 13 | | | |
| 12 | | | | 27 | 20 | 14 | | | |
| 14 | | 4 | M5x2 | 30 | 22.5 | 16.5 | | 22 | 6 |
| 15 | | | | 31 | 23.5 | 17.5 | | | |
| 16 | | | | 32 | 24.5 | 18.5 | | | |
| 17 | 33 | 25.5 | | 19.5 | 5.5 | 23 | 7 | | |
| 18 | 37 | 27.5 | | 20.5 | | | | | |
| 19 | 38 | 28.5 | | 21.5 | | | | | |
| 20 | 39 | 29.5 | 22.5 | | | | | | |
| 22 | 40 | 31.5 | 24.5 | | | | | | |
| 24 | 43 | 33.5 | 26.5 | | | | | | |
| 25 | M5 | 4 | M5x2 | 44 | 34.5 | 27.5 | 24 | 8 | |
| 28 | | | | 54 | 43 | 32 | | | |
| 30 | | | | 56 | 45 | 34 | | | |
| 32 | | | | 58 | 47 | 36 | | | |
| 35 | | | | 61 | 50 | 39 | | | |
| 38 | | | | 64 | 54 | 42 | | | 6.6 |
| 40 | M6 | 6 | M6x2 | 66 | 56 | 44 | | | |
| 42 | | | | 68 | 58 | 46 | | | |
| 45 | | | | 83 | 68 | 50 | 8.8 | 38 | 13 |
| 48 | M8 | 6 | M8x2 | 86 | 71 | 53 | | | |
| 50 | | | | 88 | 73 | 55 | | | |